

What are Valves?

Valves are mechanical devices that controls the flow and pressure within a system or process. They are essential components of a piping system that conveys liquids, gases, vapors, slurries etc..

Different types of valves are available: gate, globe, plug, ball, butterfly, check, diaphragm, pinch, pressure relief, control valves etc. Each of these types has a number of models, each with different features and functional capabilities. Some valves are self-operated while others manually or with an actuator or pneumatic or hydraulic is operated.

Functions from Valves are:

- Stopping and starting flow
- Reduce or increase a flow
- Controlling the direction of flow
- Regulating a flow or process pressure
- Relieve a pipe system of a certain pressure

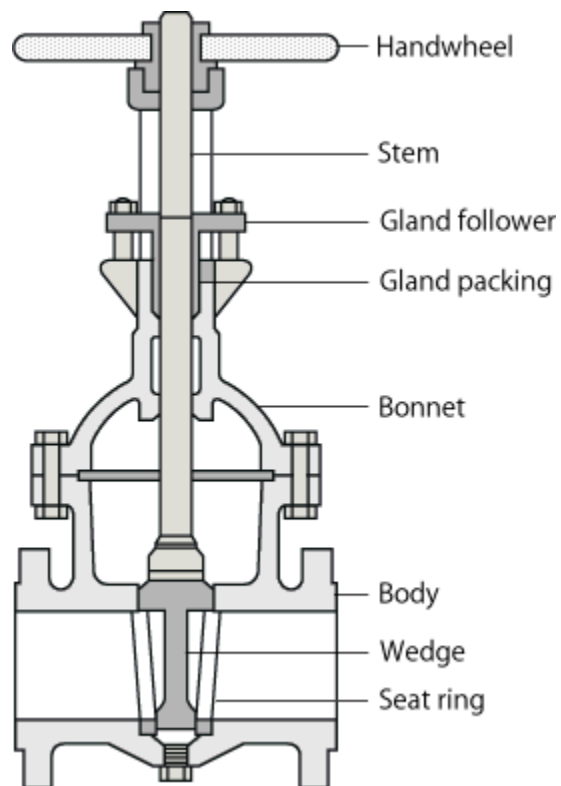

There are many valve designs, types and models, with a wide range of industrial applications. All satisfy one or more of the functions identified above. Valves are expensive items, and it is important that a correct valve is specified for the function, and must be constructed of the correct material for the process liquid.

Regardless of type, all valves have the following basic parts: the body, bonnet, trim (internal elements), actuator, and packing. The basic parts of a valve are illustrated in the image on the right.

Valve Body

The valve body, sometimes called the shell, is the primary boundary of a pressure valve. He serves as the main element of a valve assembly because it is the framework that holds all the parts together.

The body, the first pressure boundary of a valve, resists fluid pressure loads from connecting piping. It receives inlet and outlet piping through threaded, bolted, or welded joints.

The valve-body ends are designed to connect the valve to the piping or equipment nozzle by different types of end connections, such as butt or socket welded, threaded or flanged.

Valve bodies are cast or forged in a variety of forms and each component have a specific function and constructed in a material suitable for that function.



Valve Bonnet

The cover for the opening in the body is the bonnet, and it is the second most important boundary of a pressure valve. Like valve bodies, bonnets are in many designs and models available.

A bonnet acts as a cover on the valve body, is cast or forged of the same material as the body. It is commonly connected to the body by a threaded, bolted, or welded joint. During manufacture of the valve, the internal components, such as stem, disk etc., are put into the body and then the bonnet is attached to hold all parts together inside.

In all cases, the attachment of the bonnet to the body is considered a pressure boundary. This means that the weld joint or bolts that connect the bonnet to the body are pressure-retaining parts. Valve bonnets, although a necessity for most valves, represent a cause for concern. Bonnets can complicate the manufacture of valves, increase valve size, represent a significant cost portion of valve cost, and are a source for potential leakage.

Valve Trim

The removable and replaceable valve internal parts that come in contact with the flow medium are collectively termed as **Valve trim**. These parts include valve seat(s), disc, glands, spacers, guides, bushings, and internal springs. The valve body, bonnet, packing, et cetera that also come in contact with the flow medium are not considered valve trim.

A Valve's trim performance is determined by the disk and seat interface and the relation of the disk position to the seat. Because of the trim, basic motions and flow control are possible. In rotational motion trim designs, the disk slides closely past the seat to produce a change in flow opening. In linear motion trim designs, the disk lifts perpendicularly away from the seat so that an annular orifice appears.

Valve trim parts may be constructed of assorted materials because of the different properties needed to withstand different forces and conditions. Bushings and packing glands do not experience the same forces and conditions as do the valve disc and seat(s).

Flow-medium properties, chemical composition, pressure, temperature, flow rate, velocity and viscosity are some of the important considerations in selecting suitable trim materials. Trim materials may or may not be the same material as the valve body or bonnet.

[API 600 Valve's Trim No](#)

Valve Disk and Seat(s)

Disk

The disc is the part which allows, throttles, or stops flow, depending on its position. In the case of a plug or a ball valve, the disc is called plug or a ball. The disk is the third most important primary pressure boundary. With the valve closed, full system pressure is applied across the disk, and for this reason, the disk is a pressure related component.

Disks are usually forged, and in some designs, hard surfaced to provide good wear properties. Most valves are named, the design of their disks.

Seat(s)

The seat or seal rings provide the seating surface for the disk. A valve may have one or more seats. In the case of a globe or a swing-check valve, there is usually one seat, which forms a seal

with the disc to stop the flow. In the case of a gate valve, there are two seats; one on the upstream side and the other on the downstream side. A gate valve disc has two seating surfaces that come in contact with the valve seats to form a seal for stopping the flow.

To improve the wear-resistance of the seal rings, the surface is often hard-faced by welding and then machining the contact surface of the seal ring. A fine surface finish of the seating area is necessary for good sealing when the valve is closed. Seal rings are not usually considered pressure boundary parts because the body has sufficient wall thickness to withstand design pressure without relying upon the thickness of the seal rings.

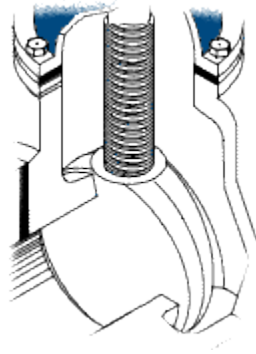

Valve Stem

The valve stem provides the necessary movement to the disc, plug or the ball for opening or closing the valve, and is responsible for the proper positioning of the disk. It is connected to the valve handwheel, actuator, or the lever at one end and on the other side to the valve disc. In gate or globe valves, linear motion of the disc is needed to open or close the valve, while in plug, ball and Butterfly valves, the disc is rotated to open or close the valve.

Stems are usually forged, and connected to the disk by threaded or other techniques. To prevent leakage, in the area of the seal, a fine surface finish of the stem is necessary.

There are five types of valve stems:

- **Rising Stem with Outside Screw and Yoke**
The exterior of the stem is threaded, while the portion of the stem in the valve is smooth. The stem threads are isolated from the flow medium by the stem packing. Two different styles of these designs are available; one with the handwheel attached to the stem, so they can rise together, and the other with a threaded sleeve that causes the stem to rise through the handwheel. This type of valve is indicated by "O. S. and Y." is a common design for NPS 2 and larger valves.
- **Rising Stem with Inside Screw**
The threaded part of the stem is inside the valve body, and the stem packing along the smooth section that is exposed to the atmosphere outside. In this case, the stem threads are in contact with the flow medium. When rotated, the stem and the handwheel to rise together to open the valve.

- **Non Rising Stem with Inside Screw**
The threaded part of the stem is inside the valve and does not rise. The valve disc travels along the stem, like a nut if the stem is rotated. Stem threads are exposed to the flow medium, and as such, are subjected to the impact. That is why this model is used when space is limited to allow linear movement, and the flow medium does not cause erosion, corrosion or abrasion of the stem material.
- **Sliding Stem**
This valve stem does not rotate or turn. It slides in and out the valve to open or close the valve. This design is used in hand-operated lever rapid opening valves. It is also used in control valves are operated by hydraulic or pneumatic cylinders.
- **Rotary Stem**
This is a commonly used model in ball, plug, and Butterfly valves. A quarter-turn motion of the stem open or close the valve.

In the main Menu "Valves" you will find some links to detailed (large) images of Rising and NON Rising Stem valves.

Valve Stem Packing

For a reliable seal between the stem and the bonnet, a gasket is needed. This is called a Packing, and it is fitted with e.g. the following components:

- Gland follower, a sleeve which compresses the packing, by a gland into the so called stuffing box.
- Gland, a kind of bushing, which compressed de packing into the stuffing box.
- Stuffing box, a chamber in which the packing is compressed.
- Packing, available in several materials, like Teflon®, elastomeric material, fibrous material etc..
- A backseat is a seating arrangement inside the bonnet. It provides a seal between the stem and bonnet and prevents system pressure from building against the valve pakking, when the valve is fully open. Back seats are often applied in gate and globe valves.

An important aspect of the life time of a valve is the sealing assembly. Almost all valves, like standard Ball, Globe, Gate, Plug and Butterfly valves have their sealing assembly based upon shear force, friction and tearing.

Therefore valve packaging must be properly happen, to prevent damage to the stem and fluid or gas loss. When a packing is too loose, the valve will leak. If the packing is too tight, it will affect the movement and possible damage to the stem.

Typical sealing assembly

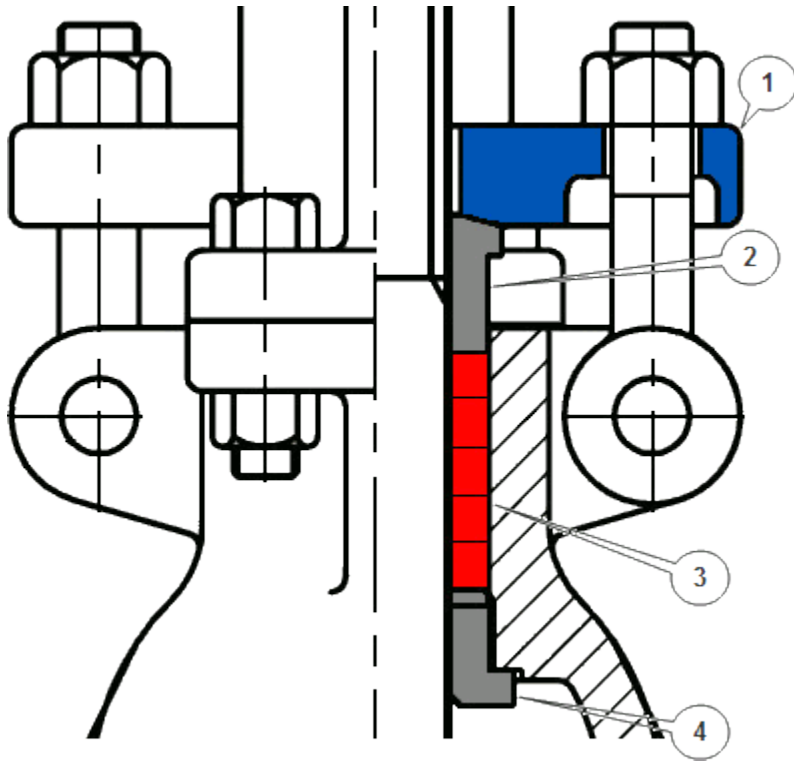

1. Gland Follower 2. Gland 3. Stuffing Box with Packing 4. Back Seat

Valve Yoke and Yoke Nut

Yoke

A Yoke connects the valve body or bonnet with the actuating mechanism. The top of the Yoke holding a Yoke nut, stem nut, or Yoke bushing and the valve stem passes through it. A Yoke usually has openings to allow access to the stuffing box, actuator links, etc.. Structurally, a Yoke must be strong enough to withstand forces, moments, and torque developed by the actuator.

Yoke Nut

A Yoke nut is an internally threaded nut and is placed in the top of a Yoke by which the stem passes. In a Gate valve e.g., the Yoke nut is turned and the stem travels up or down. In the case of Globe valves, the nut is fixed and the stem is rotated through it.

Valve Actuator

Hand-operated valves are usually equipped with a handwheel attached to the valve's stem or Yoke nut which is rotated clockwise or counter clockwise to close or open a valve. Globe and gate valves are opened and closed in this way.

Hand-operated, quarter turn valves, such as Ball, Plug or Butterfly, has a lever for actuate the valve.

There are applications where it is not possible or desirable, to actuate the valve manually by handwheel or lever. These applications include:

- Large valves that must be operated against high hydrostatic pressure
- Valves they must be operated from a remote location
- When the time for opening, closing, throttle or manually controlling the valve is longer, than required by system-design criteria

These valves are usually equipped with an actuator.

An actuator in the broadest definition is a device that produces linear and rotary motion of a source of power under the action of a source of control.

Basic actuators are used to fully open or fully close a valve. Actuators for controlling or regulating valves are given a positioning signal to move to any intermediate position. There a many different types of actuators, but the following are some of the commonly used valve actuators:

- Gear Actuators
- Electric Motor Actuators
- Pneumatic Actuators
- Hydraulic Actuators
- Solenoid Actuators

For more information about Actuators see main Menu "Valves" -Valve Actuators-

Classification of Valves

The following are some of the commonly used valve classifications, based on mechanical motion:

- **Linear Motion Valves.** The valves in which the closure member, as in gate, globe, diaphragm, pinch, and lift Check Valves, moves in a straight line to allow, stop, or throttle the flow.
- **Rotary Motion Valves.** When the valve-closure member travels along an angular or circular path, as in butterfly, ball, plug, eccentric- and Swing Check Valves, the valves are called rotary motion valves.
- **Quarter Turn Valves.** Some rotary motion valves require approximately a quarter turn, 0 through 90°, motion of the stem to go to fully open from a fully closed position or vice versa.

Classification of Valves based on Motion

Valve Types	Linear Motion	Rotary Motion	Quarter Turn
Gate	YES	NO	NO
Globe	YES	NO	NO
Plug	NO	YES	YES
Ball	NO	YES	YES
Butterfly	NO	YES	YES
Swing Check	NO	YES	NO
Diaphragm	YES	NO	NO
Pinch	YES	NO	NO
Safety	YES	NO	NO
Relief	YES	NO	NO
Valve Types	Linear Motion	Rotary Motion	Quarter Turn

Class Ratings

Pressure-temperature ratings of valves are designated by class numbers. ASME B16.34, Valves-Flanged, Threaded, and Welding End is one of the most widely used valve standards. It defines three types of classes: standard, special, and limited. ASME B16.34 covers Class 150, 300, 400, 600, 900, 1500, 2500, and 4500 valves.

Summary

On this page are defined a number of basic information from valves.

As you may have seen in the main Menu "Valves", you can find also information about several and often applied valves in Petro and chemical industry.

It can give you an impression, and good understanding of the differences between the various types of valves, and how these differences affect the valve function. It will help to a proper application of each type of valve during the design and the proper use of each type of valve during operation.